

CE DUR™

Installation Guide



*EagleTech is a division of
Burlingame Industries, Inc.*



Installation Guide

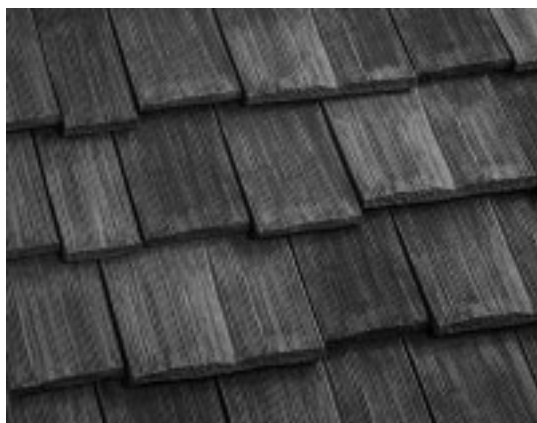

Revised January 2010

Installing CE DUR™ Shake

The CE DUR™ Shake

The revolutionary CE DUR™ Shake is a high-pressure reaction injected molded shake. It is the latest and the best of next generation, high technology roofing systems combining the beauty of natural cedar shakes with unsurpassed durability and the ease of standard shake installation methods. CE DUR™ Shake is a lightweight, fire, hail, and wind resistant product that is ideal for projects that demand a rustic cedar shake appearance.

CE DUR™ Shake is

- UL 2218 - Class 4 impact resistance
- Class "A" Fire Rated with addition of a standard cap-sheet (ASTM D-3909)
- Class "C" Rated with standard ASTM D 226 (ASTM D 4869) 30 interlay
- Rated @ a 2.17 R factor
- 100 mph wind resistant rated.
- Resistant to water absorption
- Colored throughout for stability
- Lightweight
- Resistant to rot, fungus, moss and insects
- CE DUR™ Shakes are protected by a Lifetime Transferable Limited Product Warranty.
All warranties must be registered.
- Ideal for new construction and re-roofing applications for residential and commercial projects

Design

CE DUR™ Shake is a realistic shake alternative with a 3/4" thick butt edge and tapers to 1/8". It is manufactured in three widths: 5 1/4", 7 1/4", and 12 1/4" which are reproductions of real wood/cedar shakes. They differ, however, significantly in weight. CE DUR™ Shakes provide for personal preference between architectural compatibility, roof appearance and roofing weight. Refer to the CE DUR™ Shake Technical Specifications at the end of this publication for details and coverage based on exposure and spacing between shakes.

Pitch

The minimum roof pitch for CE DUR™ Shake is a 3:12 (25%) slope. Applications below 3:12 are considered decorative. Please check with your local building official for underlayment options below 3:12.

Roof Framing

CE DUR™ Shakes lightweight system allows direct replacement of existing roof systems without the structural enhancements necessary for heavier roofing products. This also holds true for new construction. No unusual design or engineering considerations are required.

Decking

Install CE DUR™ Shake on solid decking consisting of either code-complying, 15/32" thick American Plywood Association (APA) rated plywood, APA rated wood panels, or other building materials meeting these minimum requirements in accordance with DOC PS-1 or nominal 1-by-4 or 1-by-6 solid-sawn lumber. Confirm decking requirements with your local building official.

Ice Protection

In areas where the average daily temperature in January is 25°F (-4°C) or less, an ice barrier that consists of at least two layers of underlayment cemented together or of a self-adhering polymer modified bitumen sheet, shall be in lieu of normal underlayment and extend from the eaves edge to a point at least 24 inches (610mm) inside the exterior wall line of the building.

Temperature/Cold Climates

CE DUR™ Shakes should be stored at temperatures above 40°F and pallets should not be stacked more than two pallets high if possible. CE DUR™ Shakes can be installed in low temperatures due to the composition of the product. Care should be taken when installing Ce-DUR™ Shake at temperatures below 40°F (0°C).

Underlayment

Class "A" Installation:

A base underlayment shall be installed covering the entire roof deck prior to CE DUR™ Shake installation as a temporary dry-in and/or if required by local building codes. For roofs requiring UL's Class A fire listing, one layer of standard Cap Sheet (ASDTM D 3909 / granules-up) covering the entire roof deck in addition to the above underlayment or directly on the deck if no base sheet is required. NOTE: A fiberglass cap sheet is not a waterproof underlayment. Therefore; the following interplies must be installed to make a temporary weatherproof underlayment assembly prior to shake installation. In addition to above, install one layer of ASTM D 226-type II (ASTM D 4869) 30 underlayment at the eave-line. After applying the starter, a minimum 18" wide strip of interlay of ASTM D 226-type II (ASTM D 4869) No. 30 shall be laid over the top portion of the shakes, extending up-pitch onto the sheathing and/or dry-in. Position the bottom edge of the interlay above the butt of the most recently installed shake course at a distance equal to two times the weather exposure. For example, 23.5" shakes laid with 10" exposure should have the interlay applied 20" above the installed shake butt. Installed in this manner, the interlay itself will require 1.8 times the material required for base underlayment.

Class "C" Installation:

A base underlayment shall be installed covering the entire roof deck prior to CE DUR™ Shake installation as a temporary dry-in or if required by local building codes. Install one layer of ASTM D 226-type II (ASTM D 4869) No. 30 underlayment at the eave -line. After applying the starter, a minimum 18" wide strip of interlay of ASTM D 226-type II (ASTM D 4869) No. 30 shall be laid over the top portion of the shakes, extending up-pitch onto the sheathing and/or dry-in. Position the bottom edge of the interlay above the butt of the most recently installed shake course at a distance equal to two times the weather exposure. For example, 23.5" shakes laid with 10" exposure should have the interlay applied 20" above the installed shake butt. Installed in this manner, the interlay itself will require 1.8 times the material required for base underlayment.

Non-Rated Installation

Standard #30 non-ASTM rated underlayments / interplies can be installed.

Starter

CE DUR™ Shake starter shall be installed at the eave-line. Butts of the starter shake and first course of CE DUR™ Shake shall project beyond the finished fascia as determined by conditions to insure proper water drainage. Typical installation is a 1 inch (25.4 mm) overhang. Where gutters are present, the overhang may be adjusted to insure proper water flow into the gutters.

Exposure

A 10" (254 mm) weather exposure for straight-line installations is standard, and has been used for all calculations, testing and certifications, and the product warranty is so based. When staggered installation is used, shake exposure is laid at 9" (229 mm) exposure and random shakes are at 10" (254 mm) exposure or 1" (25.4 +/-) stagger.

Spacing (Keyway)

CE DUR™ Shakes are resistant to water absorption. Therefore, expansion and contraction due to temperature or moisture content fluctuations (hot/cold, wet/dry or freeze/thaw) is negligible, thereby permitting the choice of spacing between shakes to be based on roof appearance only. The suggested standard keyway is 3/8". For details regarding other spacing, refer to the specifications section.

Installing CE DUR™ Shake

Packaging

CE DUR™ Shakes are packaged with 7 each of 5 1/4", 7 1/4", and 12 1/4" widepieces per bundle (total 21 pieces) and 23-1/2" length. When installed with a 10" weather exposure and industry standard 3/8" keyway, 168 field pieces or 8 bundles will cover 1 square. Closer spacing between shakes will require more field pieces. Refer to the Technical Specifications chart at end of this guide.

Color

CE DUR™ Shakes will, by design, shift color upon exposure to the sun. This color change takes place gradually over a three to four week period (depending on time and intensity of sun exposure) and then stabilizes at a weathered wood color for the life of the product.

Installation

CE DUR™ Shakes are applied on solid sheathing in the same manner as wood shakes, in accordance with National Roofing Contractors Association (NRCA) guidelines and applicable building codes. For details refer to drawings CS-1 and CS-2.

Workability

CE DUR™ Shake may be sawn, planed, sanded, nailed, and/or screwed with common roofing tools and materials. It will not split to width in the traditional wood shake installation manner, due to its non-fibrous and uniform composition. The shakes can also be scored with a utility knife and snapped at the score-line.

CE DUR™ Shake requires no sealing or treatment to cut edges due to its closed cell structure which permits no significant water absorption.

Fastening

Secure each CE DUR™ Shake with two standard or ring shank corrosive resistant roofing nails with a minimum 11 gauge shank and 5/16" head. Fasten a minimum 1" from shake edge and 1" to 2" above the butt line of the course to follow. Screws with a minimum 5/16" head may also be used. Fasteners shall be of sufficient length to fully penetrate a minimum of 3/4" into and or through the decking. Do not fasten through the void area between shakes and roof deck unsupported by the CE DUR™ Shake course below. Call for installation recommendations in areas where design wind speed exceeds 100 mph up to 110 mph. Non-compliance to these fastening requirements may void the warranty. See wind speed map on following page.

Hip and Ridge (pre-formed)

CE DUR™ Shakes are pre-formed one piece units with a 10" (254 mm) exposure. Two standard roofing fasteners (see fastener section) are required at the over-lap And will be covered by the next hip/ridge unit.

Pitch Range	Ridge	Hip
3:12 - 7:12	Low	Low
Above 7:12 - 11:12	Medium	Low
Above 11:12 - 14:12	High	Medium

Hip and Ridge (two-piece / field assembled)

CE DUR™ Shake supplied 5 1/4" wide field pieces should be used. The weather exposure should be same as the field of the roof. Pieces should be alternately lapped. Standard roofing gauge fasteners of sufficient length to fully penetrate roof sheathing is necessary, placed two per side, driven a minimum of 1" from each edge, and 1" to 2" above the butt line of the course to follow, so it will be concealed by the subsequent overlapping unit.

12 1/4" valley piece bundle (optional)

Bundles of 12 1/4" CE DUR™ Shakes are available as an accessory option to provide additional pieces for valley/hip cuts. This accessory option helps to minimize waste and facilitate job site production.

Snow Brackets (Optional)

Standard snow brackets should be considered in areas with high snow load requirements.

Walkability

CE DUR™ Shake has a load capacity of up to 500 pounds per square foot without distortion or breakage. However, the surface hardness and non-porous nature of CE DUR™ Shake may result in a slippery roof surface, especially on steeply pitched, new or wet roofs. Extra care and applicable safety equipment should be used at all times when walking and working on a roof.

Safety and Health

Administration (OSHA) prescribed safety standards, should be followed during installation and any subsequent roof traffic.

Flashing

Roof flashing shall not be less than No. 26 gage (0.019 inches - .048 mm) corrosion resistant sheet metal. Sections of flashing shall have an end lap of not less than 4 inches (102 mm). Single crown valley flashing shall extend 11 inches (279 mm) from the centerline each way. A 36" sweat sheet of a minimum ASTM D 226 No. 30 underlayment shall be installed in the valley prior to valley metal installation.

Chimney Step Flashing

Chimney step flashing should extend not less than 5" under the shakes and not less than 3" up the vertical surface that the shakes butt up against. A moisture-resistant barrier should be installed between galvanized flashing and masonry surfaces. Counter flashing should extend to within 1" of the finished roof surface. When chimneys, curbs, or any vertical protrusion through the roof are at least 30" wide, saddles or crickets are required. These should extend not less than 10" under the shakes. In areas with adverse weather conditions, extended lengths are required. Step flashing should be used where vertical surfaces occur in connection with slopes. Flashing should be formed of separate pieces, installed with each course of shakes, and lap no less than 3". Counter-flashing should be installed in a step manner to follow the joints of masonry and be ragged into the joints.

Dormer Flashing

Dormer flashing shall run up not less than 6" under the shakes and at least 3" up on the face and cheeks. Windows, caps, and all other projections at points where rainwater accumulates must be provided with flashing. Such flashing must extend up under the shakes of the sidewalls or other outside finish for a distance of at least 6".

Pipe Flashing

All pipes projecting through roofs must have a deck flashing and be water proofed appropriately. These flashings should extend out on the roof not less than 6". They should be of sufficient length to cover the shake course below the pipe, and extend up under the straight course above, as far as possible without being punctured by fasteners. Maintain a 1" (25.4 mm) clearance around projection.

CS-1 CE DUR™ SHAKE INSTALLATION SOLID SHEATHING

Class A or Class C Fire Rated Installation (Req. ASTM Rated underlayers)
Non-Rated Installation (Standard underlayers)

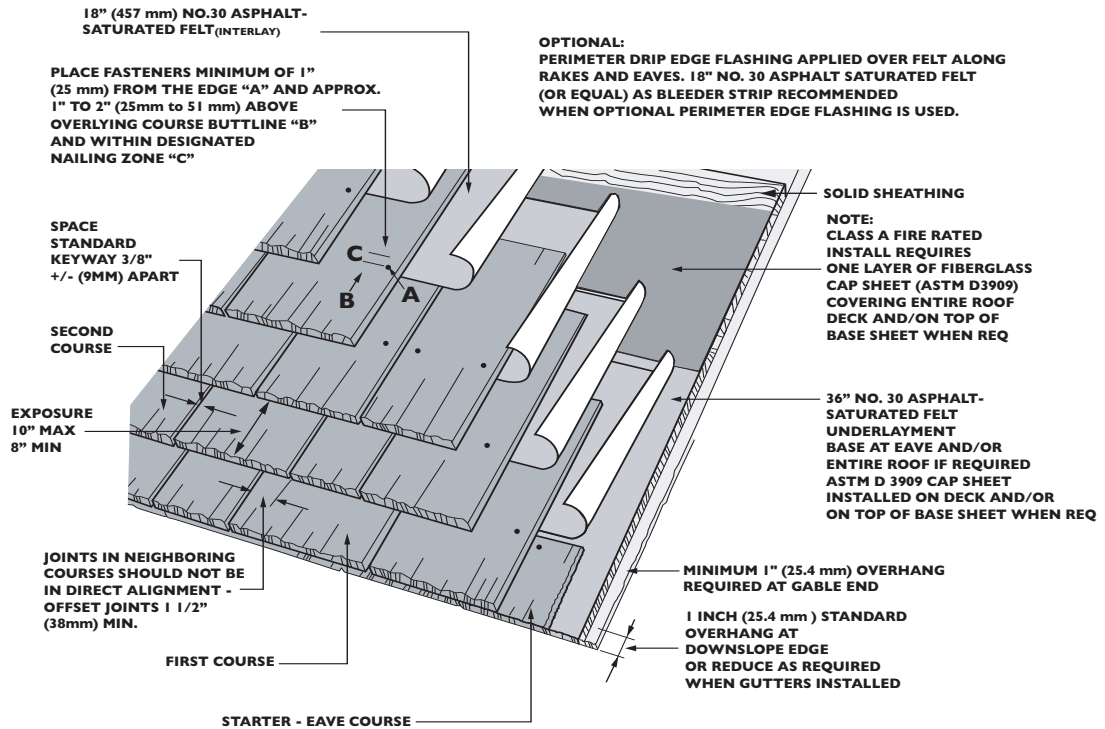

NOTE - DIMENSIONS ARE APPROXIMATE

CS-2 CE DUR™ SHAKE STAGGERED INSTALLATION SOLID SHEATHING

Class A or Class C Fire Rated Installation (Req. ASTM Rated underlayers)
Non-Rated Installation (Standard underlayers)

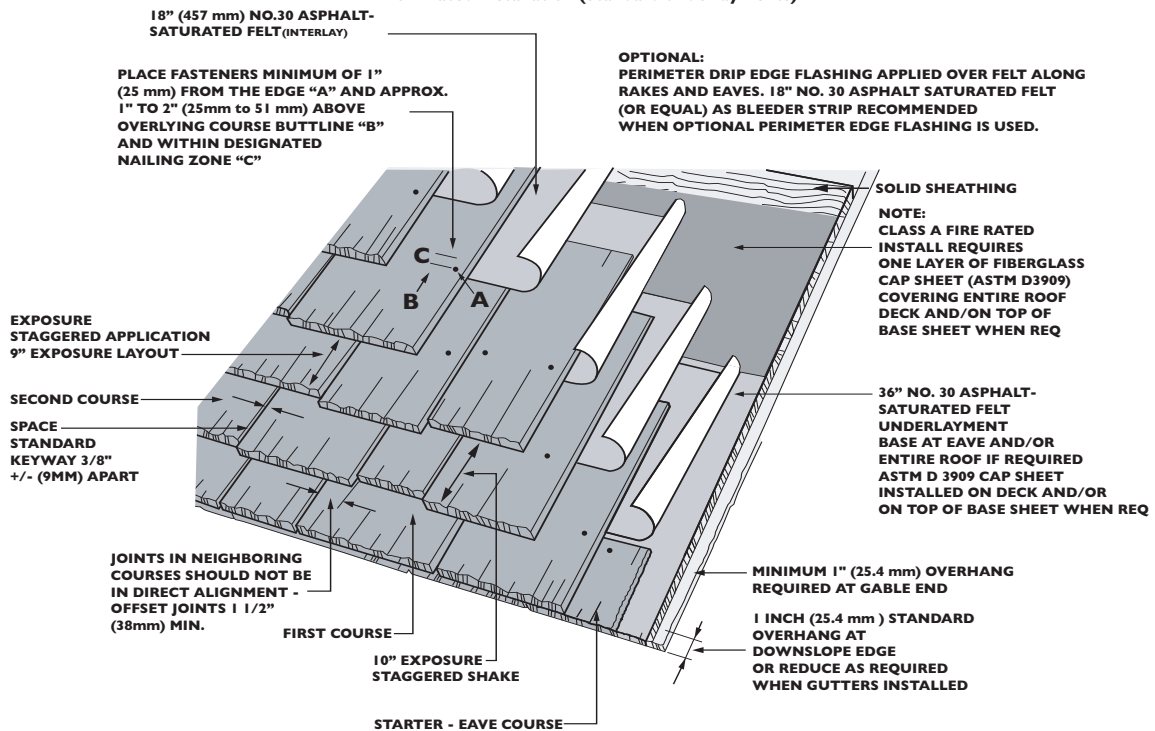

NOTE - DIMENSIONS ARE APPROXIMATE

Notes:

1. Values are nominal design 3-second gust wind speeds in miles per hour (m/s) at 33 ft (10 m) above ground for Exposure C category.
2. Linear interpolation between wind contours is permitted.
3. Islands and coastal areas outside the last contour shall use the last wind speed contour of the coastal area.
4. Mountainous terrain, gorges, ocean promontories, and special wind regions shall be examined for unusual wind conditions.

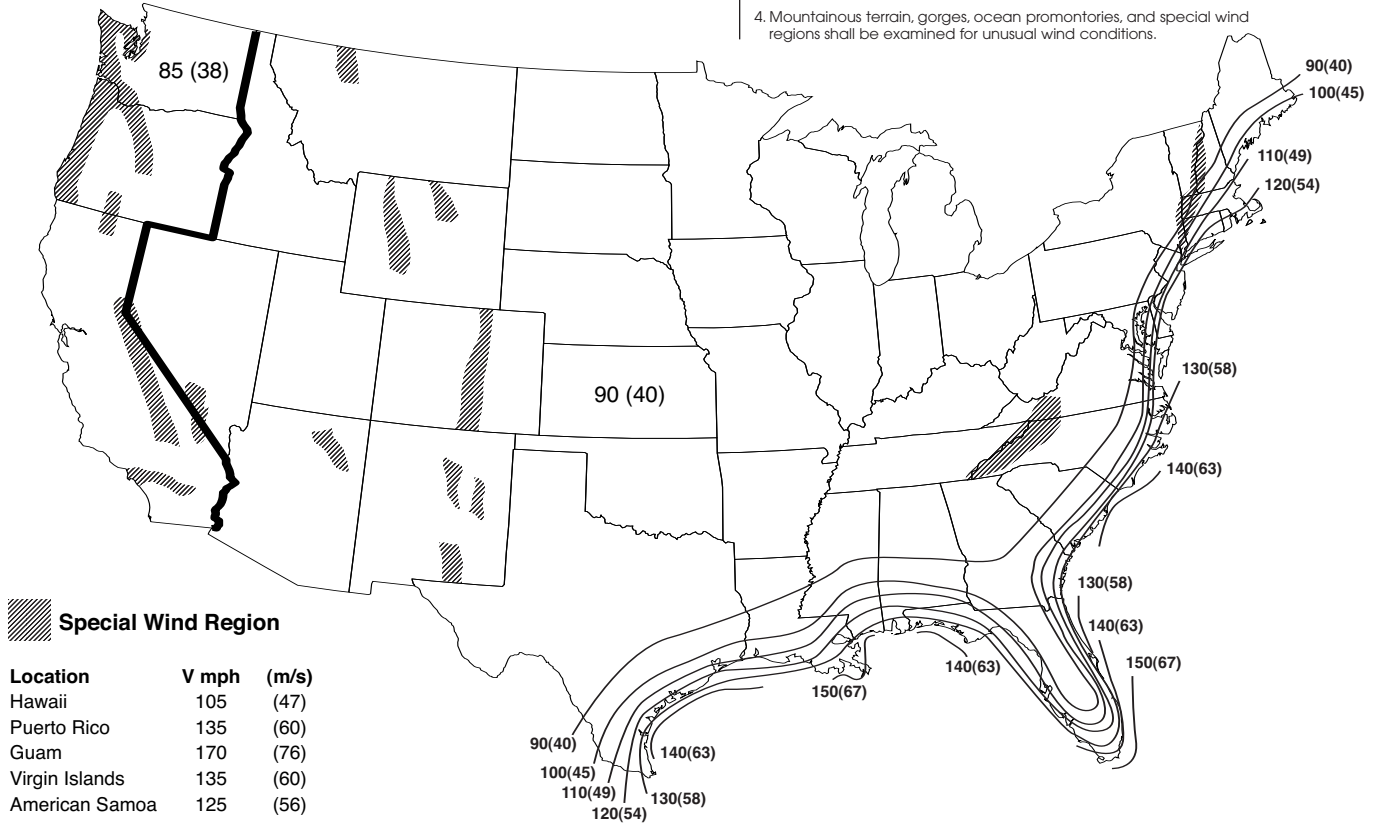

3 SECOND GUST SPEED (ASCE-7)

Product Dimensions

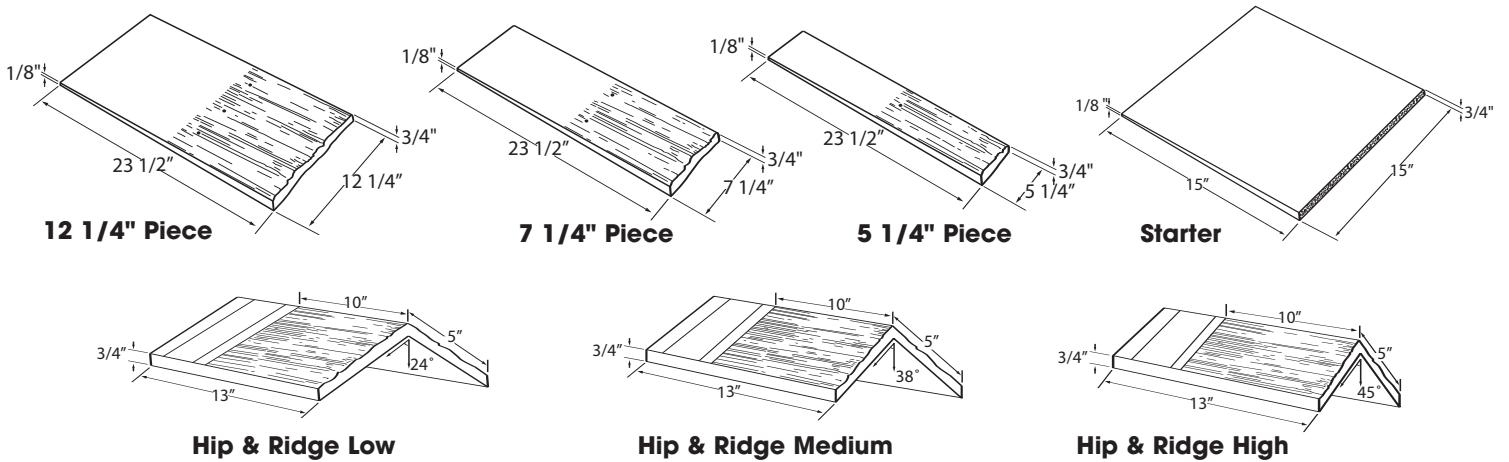

Available Sizes & Installed Weight

Length	23 1/2"
Width	5 1/4", 7 1/4", 12 1/4"
Thickness	3/4" tapered to 1/8"
Installed Weight per 100 sq. ft.	170 lbs
Pieces per Bundle	7 pieces each of 5 1/4", 7 1/4", & 12 1/4" shakes
Bundles per pallet	36

Coverage (based on 3/8" standard keyway)

10" Standard Exposure

SQ/Bundle	0.125
Pieces/SQ	168
SQ/8-Bundles	1
SQ/Pallet of 36 Bundle	4.5



These installation recommendations have been put in place only as a reference for contractors, installers and property owners.

Eagle CE DUR™ does not warrant or guarantee any workmanship, labor or performance of the roof system to include design.

It is the contractor's responsibility to see that CE DUR™ products are installed to codes, regulations and acceptable practices of the roofing trade. Eagle CE DUR™ products have a warranty which requires specific conditions be met to include registration of such with Eagle.

This warranty is available at www.eagleroofing.com or you may request from your Eagle representative.

Eagle Roofing Products Design Centers

Southern California
17875 Sky Park Circle
Suite F

Irvine, CA 92614
Phone 949 553 8333
Fax 949 553 9556

Southwest
4608 W. Elwood

Phoenix, AZ 85043
Phone 602 346 1749
Fax 602 447 0674

Northern California
9001 Foothills Blvd.
Suite 120

Roseville, CA 95747
Phone 916 789 4555
Fax 916 789 8746

Southern Florida
3100 NW Boca Raton Blvd.
Suite 401

Boca Raton, FL 33431
Phone 561 347 8180
Fax 561 347 8181

Northern Florida
402 Northlake Blvd.
Suite 1028

Altamonte Springs, FL 32701
Phone 407 691 7100
Fax 407 691 5117

Northwest Florida
13921 Icot Boulevard,
Suite 704

Clearwater, FL 33760
Phone 727 531 2266
Fax 727 531 7711

EAGLE ROOFING PRODUCTS



EagleTech is a division of Burlingame Industries, Inc.

Manufacturing, Showrooms and Stocking Yards

Southern California
2352 N. Locust Ave.
Rialto, CA 92377
Phone 800 300 3245
Fax 909 854 7181

Northern California
4555 S. McKinley
Stockton, CA 95206
Phone 800 998 3245
Fax 209 234 4366

Southwest
4602 W. Elwood
Phoenix, AZ 85043
Phone 800 346 5260
Fax 602 442 8841

Florida
1575 E. C R 470
Sumterville, FL 33585
Phone 877 300 3245
Fax 877 300 3248

South Florida Stocking Yard
1801 SW 42nd Way
Deerfield Beach, FL 33442
Phone 877-300-3245

Corporate Office 3546 N. Riverside Ave. Rialto, CA 92377 • Phone 909 822 6000 • www.eagleroofing.com

© 2010 Eagle Roofing Products 186 01/2010