

ICC-ES Evaluation Report

ESR-2530

Issued May 1, 2009

This report is subject to re-examination in one year.www.icc-es.org | (800) 423-6587 | (562) 699-0543

A Subsidiary of the International Code Council®

DIVISION: 07—THERMAL AND MOISTURE PROTECTION
Section: 07310—Roof Shingles**REPORT HOLDER:****EAGLE TECH, A DIVISION OF BURLINGAME INDUSTRIES,
INCORPORATED**
3546 NORTH RIVERSIDE AVENUE
RIALTO, CALIFORNIA 92377
(909) 822-6000
www.eagleroofing.com**EVALUATION SUBJECT****Ce•DUR® SHAKES****1.0 EVALUATION SCOPE****Compliance with the following codes:**

- 2006 *International Building Code*® (IBC)
- 2006 *International Residential Code*® (IRC)
- Other Codes (see Section 8.0)

Properties evaluated

- Weather protection
- Wind resistance
- Durability
- Fire classification

2.0 USES

Ce•DUR® Shakes are Class A or Class C roof coverings when installed in accordance with this report.

3.0 DESCRIPTION**3.1 Roof Tiles:**

3.1.1 Ce•DUR® Shakes: Ce•DUR® shakes are high-pressure reaction injected molded roof coverings that are made to look like wood shakes. There are two separate parts to the formulation; these are mixed together at the injection nozzle, and react with one another to form the finished product. The finished product is high-density, rigid, closed-cell foam plastic. Ce•DUR® shakes are produced with a length of 23.5 inches (597 mm) and widths of 5 inches (127 mm), 7 inches (178 mm) and 12 inches (305 mm). The maximum exposure is 10 inches (254 mm), resulting in an installed weight of 1.7 pounds per square foot (8.30 kg/m²). (See Figure 1.)

3.1.2 Ce•DUR® Shake Starter: Ce•DUR® shake starters are made the same as the shakes described in Section 3.1.1. The starters have a 15-inch-wide (380 mm) exposure, are 15 inches (380 mm) in length and taper from ³/₄ inch (19.1 mm) to ¹/₄ inch (6.4 mm). (See Figure 2.)

3.1.3 Ce•DUR® Hip and Ridge Shakes: Ce•DUR® preformed hip and ridge shakes are made with the same materials as the shakes described in Section 3.1.1. The preformed units are 13 inches long (330 mm) with a 10-inch (254 mm) exposure. Ce•DUR® hip and ridge shakes can also be fabricated on-site from 7-inch (178 mm) or 5-inch (127 mm) shakes. (See Figure 2.)

3.2 Fasteners:

Fasteners must be minimum No. 11 gage [0.1205 inch (3.06 mm)], ⁵/₁₆-inch-head-diameter (8 mm), corrosive-resistant roofing nails. Fasteners must be of sufficient length to penetrate into the roof sheathing a minimum of ³/₄ inch (19 mm), or through the sheathing, whichever is less.

3.3 Flashing:

Flashing must be a minimum No. 26 gage [0.019 inch (0.48 mm)] corrosive-resistant sheet metal.

3.4 Underlayment:

3.4.1 Underlayment for Class C Roof Classification: A minimum of one layer of ASTM D 226 Type II underlayment must be installed at the eave-line and a minimum 18-inch-wide strip of interply of ASTM D 226 Type II must be installed per row. (See Figure 1.)

3.4.2 Underlayment for Class A Roof Classification: A single layer of standard fiberglass cap sheet complying with ASTM D 3909 must be installed over the entire roof, in addition to the requirements in Section 3.4.1. (See Figure 1.)

3.4.3 Severe Climate Eave Underlayment: In areas where the average daily temperature in January is 25°F (-4°C) or less, an ice barrier that consists of at least two layers of underlayment, complying with ASTM D 226 Type I or ASTM D 4869, cemented together, must be installed in lieu of normal underlayment and extend from the eaves to a point at least 24 inches (610 mm) inside the exterior wall line of the building.

4.0 INSTALLATION**4.1 General:**

Ce•DUR® shakes must be installed in accordance with this report, the applicable code and the manufacturer's published installation instructions. The manufacturer's installation instructions must be available at the jobsite at all times during installation.

4.2 Slope:

The minimum roof slope for installation of the shakes is 3:12 (25 percent slope), and the maximum roof slope is 21:12 (173 percent slope).

4.3 Installation—New Construction:

The shakes must be installed on solid, minimum $1\frac{5}{32}$ -inch-thick (11.9 mm) plywood sheathing complying with the applicable code or on solid sheathing consisting of minimum nominally 1-by-4 or 1-by-6 solid-sawn lumber. Underlayment as described in Section 3.4 must be applied in accordance with the requirements of the applicable code.

4.3.1 Ce•DUR® Shake Starter: The Ce•DUR® Shake Starter is installed at the eave-line. Each starter must be attached with a minimum of two fasteners as noted in Section 3.2. (See Figure 1.)

4.3.2 Ce•DUR® Shake: The first row of shakes is installed over the starter shakes and must be attached with a minimum of two fasteners as noted in Section 3.2. Subsequent rows of shakes are installed with a maximum exposure of 10 inches (254 mm). (See Figure 1.)

4.3.3 Ce•DUR® Hip and Ridge Preformed Shakes: Underlayment must be installed with a minimum 4-inch lap (102 mm) on each side of the hip or ridge. The hip or ridge preformed shakes must be installed with a minimum of two fasteners as described in Section 3.2.

4.3.4 Ce•DUR® Site-Made Hip and Ridge Shakes: Site-made hip and ridge shakes must be made from 5-inch (127 mm) or 7-inch (178 mm) shakes. The exposure must be the same as for the field shakes. Pieces must be alternately lapped. Two standard fasteners as described in Section 3.2 must be used per side.

4.4 Fire Classification:

Roof assemblies which include the Ce•DUR® shakes, installed in accordance with this report, are recognized as Class A or Class C roof assemblies under IBC Section 1505.1 or IRC Section R902.1.

4.4.1 Class A Roof Covering: Ce•DUR® shakes provide a Class A roof covering when installed as follows:

- Deck—Minimum $1\frac{5}{32}$ -inch (11.9 mm) wood structural panel (Exposure 1)
- Maximum roof slope—Unlimited
- Underlayment—See Section 3.4.2
- Maximum shake exposure—10 inches (254 mm)

4.4.2 Class C Roof Covering: Ce•DUR® shakes provide a Class C roof covering when installed as follows:

- Deck—Minimum $1\frac{5}{32}$ -inch (11.9 mm) wood structural panel (Exposure 1)
- Maximum roof slope—Unlimited
- Underlayment—See Section 3.4.1
- Maximum shake exposure—10 inches (254 mm)

4.5 Wind Resistance:

When installed in accordance with this report, the shakes are limited to installation in areas where the maximum basic wind speed is 100 mph (161 km/h) on structures with a mean roof height of 40 feet (12 192 mm) in Exposure B areas.

4.6 Reroofing:

Prior to application of the Ce•DUR® shakes, the existing roof covering and underlayment must be completely removed. Any damaged sheathing must be replaced. The installation of the shakes must then proceed as described in Section 4.3.

5.0 CONDITIONS OF USE

The Ce•DUR® shakes described in this report comply with, or are suitable alternatives to what is specified in, those codes listed in Section 1.0 of this report, subject to the following conditions:

- 5.1** Installation must comply with this report, the manufacturer's published installation instructions and the applicable code. In the event of a conflict between the manufacturer's published instructions and this report, this report governs.
- 5.2** The use of the Ce•DUR® shakes must be limited to Exposure B areas where the wind speed and mean roof height do not exceed the limits set forth in Section 4.5.
- 5.3** Ce•DUR® shakes are manufactured in Rialto, California, under a quality control program with inspections by RI Ogawa and Associates, Inc. (AA-705).

6.0 EVIDENCE SUBMITTED

Data in accordance with the ICC-ES Acceptance Criteria for Special Roofing Systems (AC07), dated April 2007.

7.0 IDENTIFICATION

Each Ce•DUR® shake is identified with the Ce•DUR® name and the color and production date. Each bundle of shakes is labeled with the evaluation report number (ESR-2530), name of the inspection agency (RI Ogawa and Associates, Inc.), manufacturing location, contact number, color and quantity.

8.0 OTHER CODES**8.1 Evaluation Scope:**

In addition to the codes referenced in Section 1.0, the products described in this report were evaluated for compliance with the 1997 *Uniform Building Code*TM (UBC).

8.2 Uses:

See Section 2.0.

8.3 Description:

See Section 3.0, except change the wording in Section 3.4.3 to read as follows:

In areas subject to wind-driven snow, ice buildup, or wind-driven dust or sand, or in other areas as designated by the code official, solid sheathing, with two layers of Type 15 felt applied shingle-fashion and solid-cemented together with approved cementing material between the plies, must be installed in lieu of normal underlayment and extend from the eave up the roof to a point at least 36 inches (914 mm) inside the exterior wall line of the building.

8.4 Installation:

See Section 4.0, except change the wording in Sections 4.4 and 4.5 to read as follows:

Fire Classification:

Ce•DUR® shakes provide a Class A or Class C roof covering in accordance with the UBC when installed in accordance with this report.

Wind Resistance:

When installed in accordance with this report, the shakes are limited to installation in areas where the maximum wind speed is 80 mph (129 km/h) on structures with a mean roof height of 40 feet (12 192 mm) in Exposure B areas.

8.5 Conditions of Use:

The Ce•DUR® shakes described in this report comply with, or are suitable alternatives to what is specified in, the UBC, subject to the conditions noted in Section 5.0.

8.6 Evidence Submitted:

See Section 6.0.

8.7 Identification:

See Section 7.0.

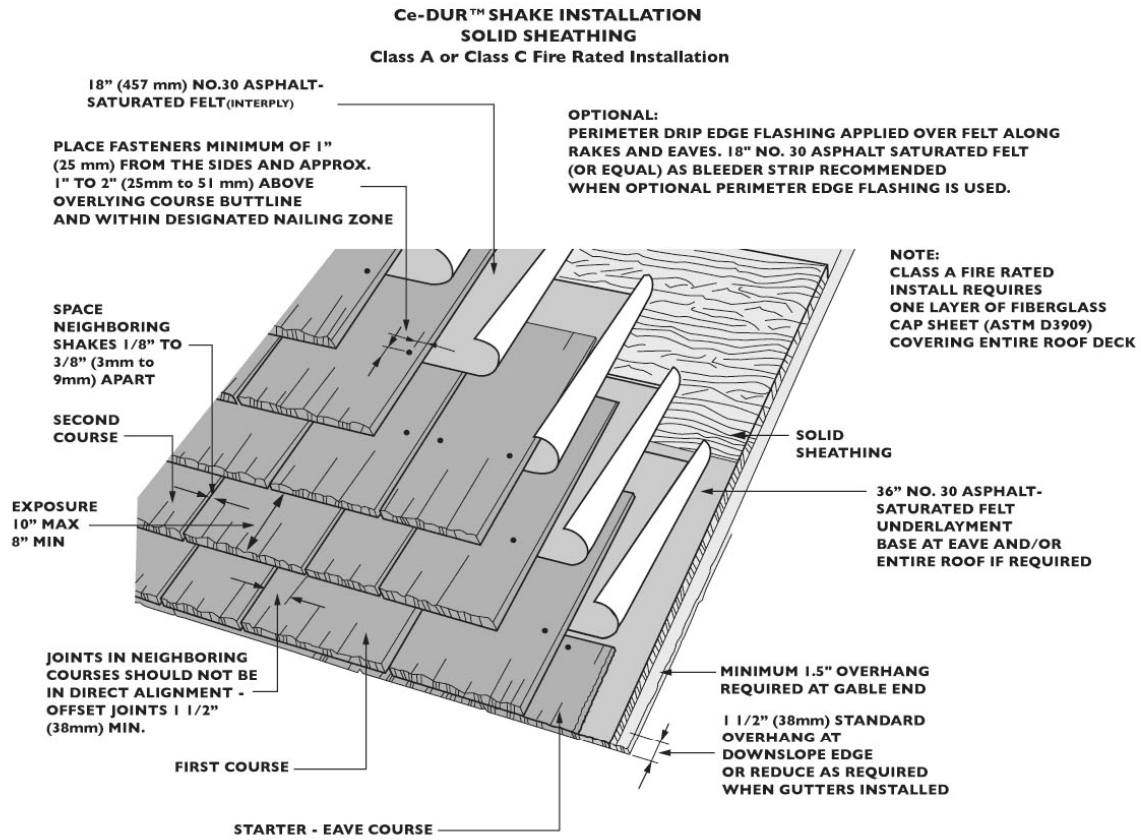

NOTE - DIMENSIONS ARE APPROXIMATE

FIGURE 1

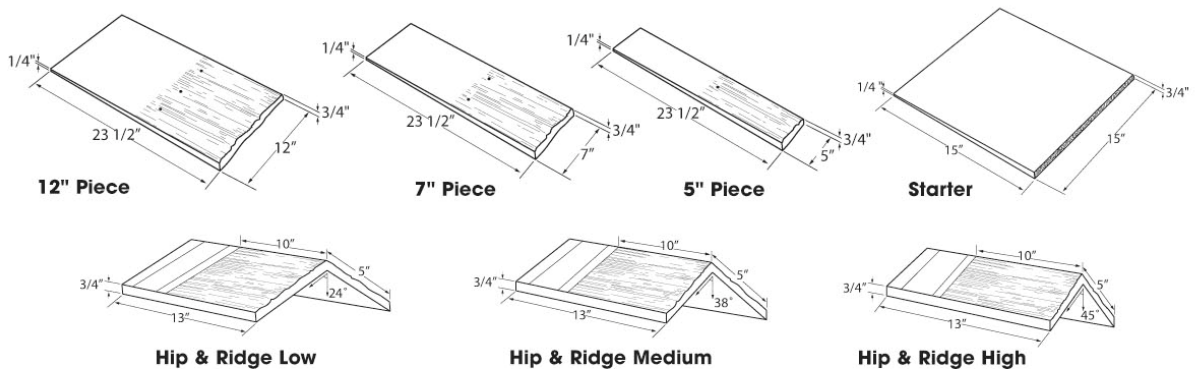

FIGURE 2